

DIANA 80

The Agora series litter bins have an elegant design, with balanced forms and different volumes, manufactured in metal or polyethylene and easily adaptable to any urban surroundings: historical centres, gardens and avenues, shopping malls and business parks.

The Agora series is available with various capacities. The 50-litre Italica litter bin is easily adaptable to any urban surroundings because of its aesthetics and dimensions. The 80-litre Diana and Atenea are more suitable for larger spaces, such as parks, avenues and shopping malls and, because of its size, the 130-litre Minerva litter bin is suitable for installation in city areas with very large public presence.

Contenur designs and manufactures Agora litter bins to procedures based on ISO 9001, and the Environmental Management System also has ISO 14001 Quality Management certification.

The Contenur Group guarantees the quality of all its products and installations and on request can also offer clients end-to-end product maintenance, including labour and materials. For more information, please contact our Technical Sales network.

Litter bins

DIANA 80

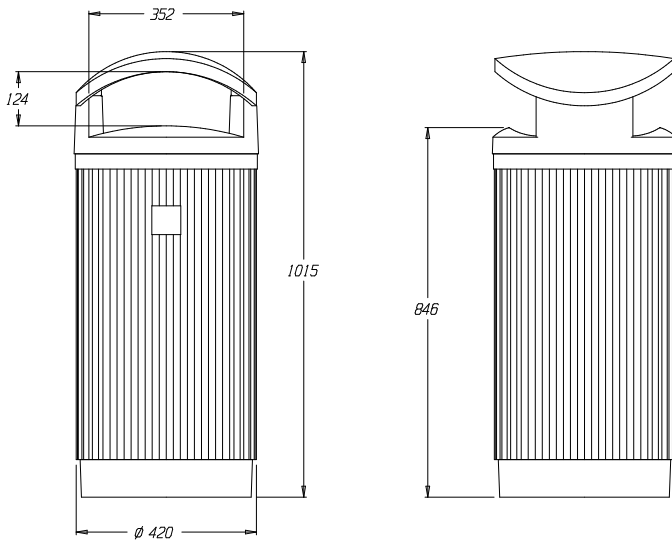

| | |
|-----------------------------|-----------|
| Nominal Capacity | 80 litres |
| Total Height | 1015 mm |
| Basket Capacity | 65 litres |
| Maximum Diameter | 420 mm |
| Total Weight Without Basket | 29.50 kg |

TECHNICAL FEATURES

Body, top, base and upper reinforcing rim made of cast sand-blasted aluminium, painted ironoxide grey. All metal parts are made of stainless steel or cast aluminium to prevent corrosion.

The filling area consists of a fixed top cover joined vertically by two side panels to a lower ring, integral with the body, forming two openings, accessible at 180°, for depositing litter.

The circular 80 litre body into which the litter is deposited houses the door for emptying. A locking system with a standard triangular key is provided to prevent unauthorized access.

Integral cigarette stubber; ashtray can be supplied on request.

65 l basket has a reinforced ring in the upper part and is fitted with an integral handle to make emptying easier for maintenance staff.

There is the option of replacing the basket with a refuse sack. The system can also be used to segregate two separate materials if a two-compartment basket is fitted.

Anti-vandal support base is integrated into the body and is fixed to the pavement simply and securely by means of six 12mm universal expansion bolts.

Latest advances in anti-vandal technology provide a tougher body and more secure locking.

Low maintenance, with the smooth surface facilitating easier cleaning.

They are designed with vertical fluting that reinforces the whole assembly providing originality and elegance. This fluting makes it difficult to stick posters and labels to the body of the bin.

Standard distribution colour: Ironoxide grey.

Can be customised by means of a badge affixed to the body, maximum size 120 x 120 mm.

Packaged in a cardboard box with the Contenur logo in black and stacked on a pallet 1820 x 1200 x 1900 mm.

The product is supplied ready-assembled for ease of transport and rapid installation

Supplied By:

Merlin

Industrial Products Ltd
sales@merlin-industrial.co.uk

Call 0845 124 9955 Fax 0845 125 9955